

# RAILWAY ENGINEERING – 2011

## Registration Form

I/We wish to register as either a Presenting Author or Delegate at **Railway Engineering – 2011** at the registration rate for 2 days of

	Early*:	Late:
Delegate (incl. VAT)	£420	£495
Presenting Author (incl. VAT)	£345	£420

\*Early rates only apply to registration fees paid before 31st March 2011.

**Registration Fee** includes attendance at Conference Sessions, Morning Coffee, Lunch, Tea, and one copy of the Proceedings on CD-Rom.

**Conference Dinner** at the East India Club, St James's Square, London @ £85 per person (inc. VAT)

Registration fee	.....
Conference Dinner	.....
<b>Total fee</b>	<b>£</b> .....

# RAILWAY ENGINEERING – 2011

11th International Conference and Exhibition

**6th – 7th July 2011**

Venue: University of Westminster, 35 Marylebone Road, London NW1, UK

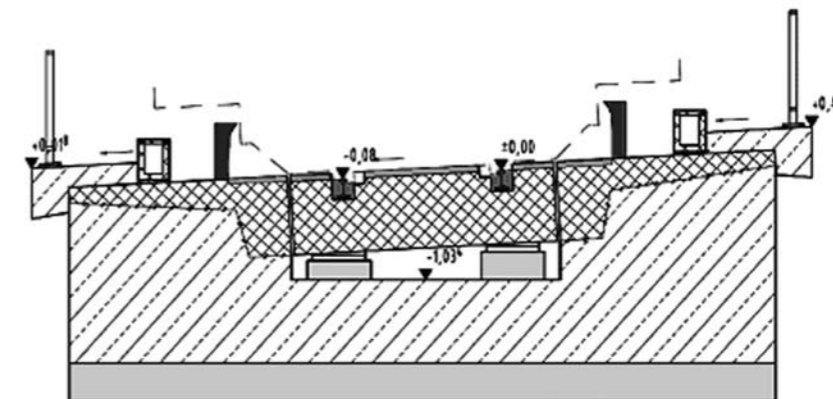

**“Maintenance + Renewal of Permanent Way, Points, Power + Signalling, Structures + Earthworks”**

Sponsored by



**“CALL FOR PAPERS”**

**Abstract Deadline: 30th November 2010**

[editor@railwayengineering.com](mailto:editor@railwayengineering.com)

[www.railwayengineering.com](http://www.railwayengineering.com)

I/We enclose a Sterling cheque/banker's draft drawn on a UK Clearing Bank for £ ..... made payable to *ECS Publications*,

or

Please circle: VISA / MASTERCARD / AMEX

Account Number

Card expiry date

 / 

Security code

Amount

Signature

**Cardholder name and address (BLOCK CAPITALS)**

Name and title .....

Organisation .....

Address .....

City .....

Postcode..... Country.....

email: .....

**Accommodation:**

Reduced rate 3\* + 4\* hotels

– please send details

**Exhibition:**

I wish to register as an Exhibitor

Please send details of exhibiting



**Delegate name and title** .....

Organisation .....

Address .....

City .....Postcode..... Country.....

email: .....

Tel.....Fax.....

**Delegate Cancellation Policy:** before 7th June 2011 – full refund less £30 administration charge; 8th June and thereafter – delegate substitutions accepted, but no refunds available.

**Conference Cancellation Policy:** ECS Publications, the Conference & Exhibition Organisers, reserve the right to reschedule the Conference & Exhibition in the circumstances of “events beyond our reasonable control”; ECS Publications shall not be liable for the consequences of “events beyond our reasonable control” – see definitions on our web site. ECS Publications, reserve the right to cancel the Conference & Exhibition, for reasons other than “events beyond our reasonable control”, and in that instance only, shall refund to each Participant the Conference and/or Exhibition fee, previously paid, in full satisfaction of all liabilities of ECS Publications to each Delegate or Exhibitor.

Fax your reply to (UK): +44-(0)131-452-8596, or post to:

Conference Secretariat, ECS Publications, 46 Cluny Gardens, Edinburgh EH10 6BN, UK  
email: [secretariat@railwayengineering.com](mailto:secretariat@railwayengineering.com)

## Conference Awards

Awards will be made to the best papers in the following categories:

- (1) **Railway Engineering Award** for the best paper on Engineering Applications
- (2) **Railway Gazette International Innovation Award:** to be made for the best paper on Innovation in the Railway Industry
- (3) **Geophysics & NDT Award:** to be made by for the best paper on the use of geophysical or NDT techniques for investigating permanent way or structures.
- (4) **Research Award:** to be presented for the best paper by a University researcher.

To be eligible for a Conference Award, authors must register for the Conference and present their paper.

## Scientific Advisory Board

Dr EOA Awoleye, Trackground Limited, York, UK  
R Becker, Plasser & Theurer, Vienna, Austria  
Dr MR Clark, Halcrow, Dubai  
Dr AP de Man, Edilon)( Sedra, Haarlem, The Netherlands  
Prof M Dhanasekar, QUT, Brisbane, Australia  
BM Ede, TTCI, Pueblo, CO, USA  
Prof MC Forde, University of Edinburgh, UK  
Dr A Giannopoulos, University of Edinburgh, UK  
A Green, Carillion plc, Wolverhampton, UK  
Dr DA Gunn, British Geological Survey, Keyworth, UK  
Dr K Hrubec, G Impuls, Prague, Czech Republic  
Dr J Hyslip, Hyground Engineering Inc, Williamsburg, MA, USA  
Prof E Hohnecker, University of Karlsruhe, Germany  
J Hugenschmidt, EMPA, Switzerland  
Dr G Hunt, Delta Rail, Derby, UK  
Dr T Ishikawa, East Japan Railway Company, Japan  
CMA Jackson, Railway Gazette International, Sutton, UK  
Dr J Jaiswal, Corus, Rotherham, UK

Dr B Kufver, Ferroplan, Stockholm, Sweden  
A Lau, Mass Transit Corporation, Hong Kong, China  
Prof Q Leiper, Carillion plc, Wolverhampton, UK  
Dr A Massel, Railway Scientific & Technical Centre, Warsaw, Poland  
H McAnaw, Metronet Rail BCV, London, UK  
M Miwa, Railway Technical Research Institute, Japan  
Dr A Reinschmidt, TTCI, Pueblo, CO, USA  
Dr I Robertson, Alstom, France  
Dr JG Rose, University of Kentucky, KY, USA  
Dr W Schoech, Speno International SA, Geneva, Switzerland  
Prof R Smith, Imperial College, London, UK  
Dr SD Smith, University of Edinburgh, UK  
Dr TR Sussman, US DOT, MA, USA  
MJ Taylor, FaberMaunsell, Beckenham, UK  
R Winfield, Network Rail, London, UK  
J Wood, Delta Rail, Derby, UK  
Dr PK Woodward, Heriot-Watt University, Edinburgh, UK

## Exhibition

**FREE EXHIBITION VISITOR TICKET: see form overleaf**

At the Tenth International Conference in 2009, Exhibitors included:

Allied Associates Geophysical Ltd  
Aqua Group Ltd  
Arup  
Balfour Beatty Rail Technologies Ltd  
Blom Aerofilms Limited  
Deltarail Group Limited  
Dow Hyperlast  
Edilon)(Sedra International BV  
Fugro Aperio  
Geofabrics Limited  
Georgetown Rail Equipment Co  
GERB Engineering GmbH & Co KG  
GGR UNIC Ltd

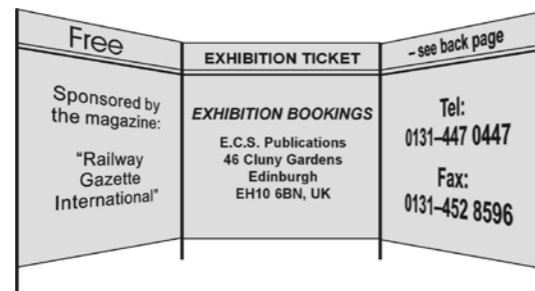

GSSI Inc  
IDS UK  
Olympus  
Railway Gazette International  
Straininstall UK Ltd  
Strand7 UK Limited  
Systra  
Tam International  
University of Edinburgh  
Vortok International  
WTB Geotechnics  
Xitrack Ltd  
Zetica Ltd

A major feature of the Eleventh International Conference will be the "State-of-the-Art" Exhibition which will be open to visitors.

**2-Day Exhibition Fee = £980 + VAT for 3m x 2m Exhibition space**  
**50% deposit required with booking**

Exhibition Registration: Conference Secretariat, ECS Publications  
46 Cluny Gardens, Edinburgh EH10 6BN, UK

Tel: 0131-447 0447 • Fax: 0131-452 8596 • email: exhibition@railwayengineering.com

[www.railwayengineering.com](http://www.railwayengineering.com)

## "Call for Papers"

### "Maintenance + Renewal of Permanent Way, Points, Power + Signalling, Structures + Earthworks"

The conference will be divide into two themes as below – each theme will be spread over two days, to allow participants maximum opportunity to hear as many papers as possible in their theme of interest. Papers are invited on the following and related topics:

#### Theme-1: Permanent Way, Rail Maintenance, Signalling & Electrification

- **Assets**  
Asset databases  
Systems engineering  
Whole-life costing  
Reliability analysis  
Maintenance resourcing
- **Management**  
Track asset management  
Journey time improvement
- **Track**  
Investigation & analysis  
Track design  
High speed track, including tilting trains  
Track maintenance & monitoring  
Ballast life & maintenance  
Heavy haul issues  
Formation treatment  
Ballastless track  
New concepts of track bed  
Sleeper/Tie design & track fastening  
Points/switch maintenance and failures
- **Light Rail:**  
Design  
Maintenance  
Cost savings
- **Rail**  
Performance and failures  
Rail maintenance & improvement  
Rail inspection technology  
Rail steels - metallurgy & hardening  
Gauge corner cracking  
Wheel/rail interaction  
Heavy haul issues  
Rail grinding  
Life prediction
- **Signalling**  
New technology in Signalling  
TPWS & ETCS  
Economics of Signalling  
Safety
- **Electrification & Lighting**
- **Safety Integrity Levels (SILs)**
- **Heavy Haul Issues**
- **High Speed Rail Issues**
- **Case Studies**

#### Theme-2 Railway Structures & Earthworks

- **Assets**  
Asset databases  
Whole-life costing  
Reliability analysis
- **Bridges**  
Investigation of Railway Bridges  
Steel & Iron Railroad Bridges  
Concrete & Post-tensioned Concrete Bridges  
Masonry Arch Rail Bridges  
NDT of Rail Bridges  
Heavy Haul Bridges  
Repair Procedures  
Advanced Composites in Rail Bridge Repair
- **Retaining Walls**  
Investigation & Repair
- **Tunnels**  
Investigation & Repair  
Fire in Rail Tunnels
- **Earthworks**  
Embankments & slopes  
Heavy haul embankments  
Condition monitoring of embankments  
Stabilising earthworks  
Control of vegetation
- **Foundation solutions**  
Piled foundations
- **Heavy Haul issues**
- **Contamination Clean-up**
- **Station Renewal**
- **Safety & Access Issues**
- **Case Studies**

**A selection of the best papers will be considered for publication in the Elsevier Science Journals:**  
*Construction + Building Materials*  
or  
*NDT+E International*

### SUBMISSION OF ABSTRACTS

Short to medium length contributions from practising engineers will be particularly welcome – in addition to papers from university researchers.

**Deadline: Abstracts of Papers (200 words) should be submitted, not later than 30th November 2010, to:**

Professor M.C. Forde, PhD, FREng, FRSE, CEng, FICE, FIEE  
Carillion Professor, University of Edinburgh, School of Engineering  
The Kings Buildings, Edinburgh EH9 3JL, Scotland, UK  
Fax: +44-(0)131-452-8596 • email: editor@railwayengineering.com